

A review of the causes, impacts and solutions for electricity supply crises in Brazil

Julian David Hunt.^{a,*}, Daniel Stilpen^b, Marcos Aurélio Vasconcelos de Freitas^b

^a International Institute for Applied Systems Analysis, IIASA, Scholssplatz 1, A-2361, Austria

^b Energy Planning Program/COPPE/UF RJ, Brazil

ARTICLE INFO

Keywords:

Electricity crisis
Water crisis
Energy security
Climate change adaptation

ABSTRACT

From the end of 2013 to the end of 2015, Brazil faced serious challenges to supply its demand for electricity due to a prolonged drought in the Southeast and Northeast regions with the consequent loss of hydroelectric generation. This paper presents an historical analysis of major world energy crises from 1988 to 2015 and in Brazil from 1924 to 2015. Analysing the natural river flow of key Brazilian dams from 1931 until 2017, this paper suggests that hydropower generation in Brazil has a 10–15 years cyclical pattern of hydropower generation. The periods of drought in this cyclical pattern usually coincides with energy crises due to the reduction in hydropower generation. It was found that the drought in 2015 had an impact of 110 TWh in hydropower generation, from which 25 TWh are due to head loss and 70 TWh are from lack of stored hydropower in July of 2014. In addition, 48 TWh were not generated due to delays in the construction of new power plants. Other causes of the Brazilian energy crisis of 2015 are presented and the overall electricity generation impact of these causes are compared. In addition, this paper presents the impacts on the energy, water and food supply sectors in Brazil, and the strategies employed to reduce the impact of the crises. With the intention of preventing future energy crises, the paper then shows the potential alternatives to improve electricity supply security in Brazil, particularly in terms of diversifying and widening the share of renewable sources and increasing the energy storage potential of the country.

1. Introduction

Electricity sector crises originate for different reasons, such as Nuclear power disasters, for example, in Fukushima, Japan [1], unregulated energy markets as in California [2,3] and Chile [4], rapid surge electricity demand and sluggish investments in the electricity sector as in Pakistan [5–8] and Bangladesh [9], macroeconomic crisis as in Argentina [10], extended droughts affecting hydroelectric generation as in Nepal [11] and Brazil [12]. Details on the major causes and resulting actions for these crises are presented in [13–16]. Looking at the bigger picture there is a global energy change happening with the aim to replace fossil fuel alternatives for renewable energy sources, with all the resulting consequences [17].

With the intention of providing secure [18] and affordable electricity supply services, countries have implemented regulatory reforms in the electricity supply industry [10,19]. However, some regulations are applicable to one country but not to others [20]. Electricity supply

and crisis management is a particularly complex issue in developing countries in Africa, such as Ghana, Cameroon, Ethiopia, where most of the population does not have access to electricity [21,22].

This paper attempts to describe some of the causes and impacts of the energy and water crises in Brazil, and proposes some suggestions for improvement. The main contributions of this paper are to highlight that Brazil has been suffering from an energy crisis with a frequency of 10–15 years, i.e. the years 1924, 1944, 1955, 1964, 1986, 2001 and 2015. This crisis pattern is due to systematic and climatic problems that should be resolved with short, medium and long-term measures as proposed in this article. In addition, this article highlights the main impacts from the energy and water crises so that strategies can be made to better prepare for future crises, and propose possible solutions to prevent future energy crises.

Historically, the power sector in Brazil has been plagued by multiple power crises of different duration and geographical scope. In the great majority of the cases, the causes of the crises were associated with

Abbreviations: ANEEL, Brazilian Electricity Regulatory Agency; ECS, Energy Crop Storage; EPE, Energy Research Office; GDP, Gross Domestic Product; IBGE, Brazilian Institute of Geography and Statistics; ONS, Brazilian Electricity Grid Operator; PDE, Ten-Year Energy Plan; PLD, Spot Market Electricity Price; SIN, Brazilian Interconnected Electricity System; SPS, Seasonal-Pumped-Storage

* Corresponding author.

E-mail addresses: hunt@iiasa.ac.at (J.D. Hunt.), stilpen@ppe.ufjr.br (D. Stilpen), mfreitas@ppe.ufjr.br (M.A.V. de Freitas).

Table 1
Previous crises in Brazil and their main causes [13,24,27].

Period	State/Regions	Major causes
1924–1925	São Paulo	Drought in Tietê river and its tributaries.
1938–1947	São Paulo	Difficulty to import equipment due to World War II.
1950–1957	Southeast	Drought and demand increase.
1951–1964 (intermittent)	Rio de Janeiro	Drought in Paraíba river and lack of generation capacity.
1963–1964	São Paulo Rio de Janeiro	Drought: drastic reduction in river flow in the Paraíba and Pirai rivers.
1967	Rio de Janeiro	Flooding of Nilo Peçanha Plant.
1986	South	Drought in the Southern Region.
1987–1988	Northeast	Drought in the Northeast Region.
1995–1999	Manaus	Lack of investment due to poor regulations.
2001–2002	Nationwide, except in the South Region	Drought in the Southeast, Northeast and North regions, and delay in the expansion of thermal generation and transmission lines.
2014–2015	Nationwide	Drought in the Southeast, Northeast, South and North regions.

climatic conditions, since Brazil has historically been very dependent on hydroelectricity [13]. The first recorded energy crisis in Brazil happened in 1924–1925 with a drought in the Tietê river and affected the city of São Paulo. Table 1 presents the previous crises in Brazil, including their respective reasons and the main impacted regions. Another intense energy crisis happened between 1953 and 1955, when the hydropower stored in the reservoirs reached very low levels and there was energy rationing in the cities of São Paulo and Rio de Janeiro. The power outages reached 5–7 h a day in Rio de Janeiro. In São Paulo power cuts, without prior notice to the public, were quite common [23]. Both cities were again subject to rationing in 1963 and 1964, as the country faced an accelerated growth in the consumption of electricity and the investments failed to attend the increase in consumption [24]. In 1986, the Southeast region was threatened by electricity rationing, as occurred in the South region in the same year [13]. Emergency measures were taken, such as daylight saving time throughout the national territory [25]. Rationing also occurred in the Northeast between March 1987 and January 1988 due to two basic causes: the first, due to the low volume of water in the São Francisco basin and the second due to the delay in schedules of planned hydroelectric projects, caused by financial problems [13,26].

In 2001, five years after reforms in the energy sector, Brazil went through a severe energy crisis, which by far dwarfed the previous crises in size, duration, geographical scope and complexity [13]. A dry summer¹ arrived when the water levels of the Brazilian dam system were at low levels, leading to a water shortage that culminated in a rationing of electricity consumption with penalties for over-consumption. Unclear market rules led to major lawsuits from different parties, leaving the electricity market in chaos. The official government explanation for the crisis was the unexpected drought of the first months of 2001 that added to a series of unfavourable rain falls in the previous years, 1999 and 2000, leading to the acute water shortage of 2001 [28]. The maximum storage levels for each year were 1998 – 83%, 1999 – 70%, 2000 – 59%, 2001 – 41% [29].

From June 2001 to February 2002, Brazilians were obliged to restrict electricity usage by 20%, on average. During the 1990–2000 period, there was an increase of 52.3% in electricity consumption, whereas total generation capacity increased by only 41.2%. The gap between consumption and installed capacity contributed to the inevitable collapse in 2001 [30].

Several papers have been published about the 2001 energy-rationing crisis. Franchito and Rao (2008) [31] proposed a climatological methodology to predict droughts in the Southeast of Brazil so that the energy sector can respond appropriately to reduce its impact. Simões and Barros (2007) [32] highlighted that loss of water through evaporation-transpiration impacts hydropower generation during a drought, increasing its vulnerability to changes in climate. Souza and

Soares (2007) [33] argued that the electricity demand was not significantly reduced through electricity conservation campaigns and the Government's request to reduce consumption. It only leads to a considerable reduction when compulsory electricity cut-offs would be implemented if the customer did not reduce consumption. Araújo (2006) [12] gives a detailed analysis of the Brazilian energy market reform, its impact on the 2001 crisis and also lists the causes [34]. Cavaliero and Silva (2005) [35] argued that the 2001 crisis increased debate on the need to diversify the grid, reducing the share of hydropower and increasing generation from other renewable energy sources, which is similar to what is happening at present. Other authors blame the crisis of 2001 on unfinished structural and institutional reforms [36–42] and on gas-fired power development project finance issues [43–45].

As shown in Fig. 1, in July 2001, the monthly demand had to be considerably reduced, because there was not enough energy stored in the Southeast hydropower dams to safely guarantee electricity supply for the following years. The government then decided to reduce energy consumption for residential consumers by 20% and for industrial and commercial consumers by 15–25%, depending on the importance of the economic activity [46], so that the demand would fall and the reservoirs could then fill up again [33]. The Aluminium industry suffered the hardest impact from energy rationing [47], other industries also suffered with the crisis, including the paper industry [48]. The impact of the energy crisis could even be seen from space at night, due to the reduction in lighting [49]. During this period, energy efficiency programs were established for people switching from incandescent lightbulbs to fluorescent lightbulbs [35], to replace old refrigerators for more efficient models, among other energy saving measures. This resulted in a considerable demand reduction. As it can be seen in Fig. 1, the demand only returned to previous levels in 2004 as the energy and economic crisis reduced the demand for electricity.

Since 2001 much has happened to reduce the risks of a new energy crisis. Transmission lines were installed, increasing the ability to transfer electricity from one region to another (in 2001, the energy that could have been generated in the South or in the North could not be transferred to the Southeast and Northeast due to lack of transmission lines). The country also received considerable generation capacity reinforcement, which reached 42 GW of thermoelectric power plants and other renewables in 2014 [51].

Even with these improvements to the Brazilian energy sector, in 2015 a similar trend happened due to a severe drought on the Southeast and Northeast regions caused by climate variability or climate change. The volume of water in the reservoirs fell below that of 2001, to 19%. As Brazil is still heavily reliant on hydropower generation, the hydropower generation share decreased from 91.9% to 71.3% between 2011 and 2015 [52], as shown in Fig. 2.

Hydropower reservoirs reached dangerously low operational levels that forced the Brazilian Electricity Grid Operator (ONS), to halt hydropower generation in the dams that exceeded its dead storage volume. To meet the demand, most available thermal power plants in the

¹ Summer is the rainy season for most part of Brazil.

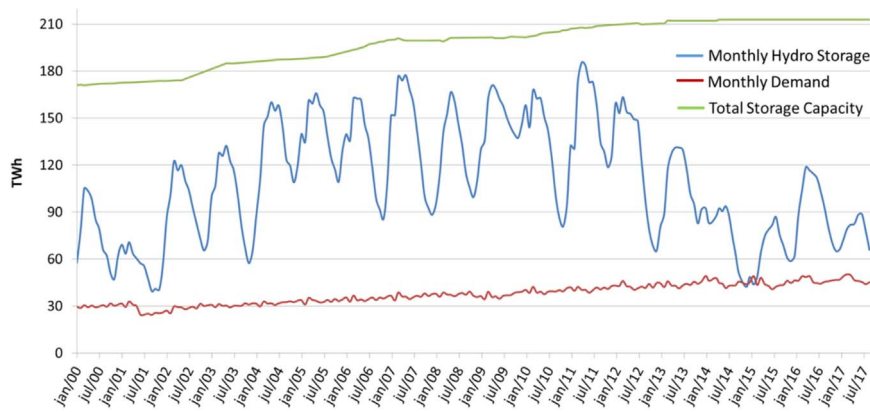

Fig. 1. Monthly hydropower storage, demand and total storage capacity in Brazil [50].

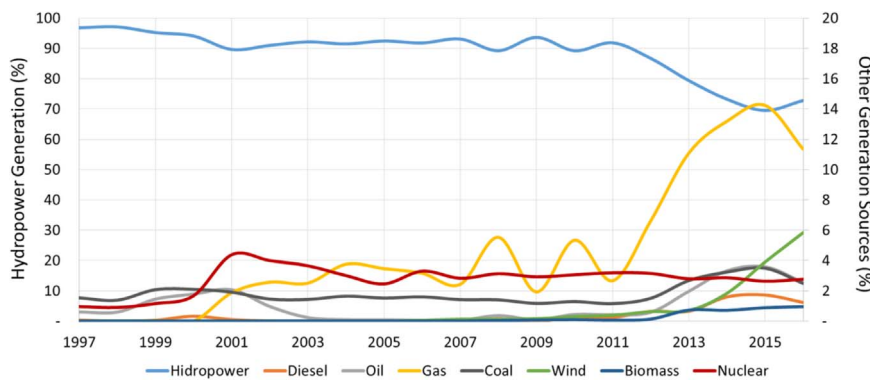

Fig. 2. Electricity generation in Brazil by energy source from 1997 to 2015 (hydropower in the left axis and other generation sources at the right axis) [52].

country were required to operate as base load in order to avoid electricity blackouts. However, this resulted in a 50–70% increase in electricity tariffs [53], and worsened the economic crisis in the country. This electricity supply costs increase during electricity generation deficit periods in Brazil has been modelled by Carpio [54].

This article is divided into six main sections. Section 2 explains some of the major causes of electricity crisis of 2015 and focus on seven particular causes to the crisis. There is an attempt to compare the contribution of each cause to the crisis. This is performed with the calculation of the overall electricity generation impact that each cause contributed to the crisis. Section 3 presents some of the impacts of the energy and water crises. These impacts focus on the supply of energy, water and food. Section 4 presents some suggestions from the literature and from the authors’ personal analysis to prevent future energy crises. Section 5 discusses the main findings of the paper and Section 6 concludes the paper.

2. Causes of the 2015 energy and water crisis

The methodology used to quantify the causes of the energy crisis in Brazil compares a year with average operation (i.e. 2012) in the

electricity sector with the crisis years (2014 and 2015). This comparison quantifies the amount of electricity supply reduction resulted from each cause that contributed to the crisis in TWh. Some causes of the 2001 crisis, which also applies to the 2015 crisis, such as lack of appropriate backup thermoelectric generation, unstructured energy reforms, lack of investment in additional generation capacity and others are discussed and referenced in the introduction section. The main causes for the energy crisis in Brazil in 2015 discussed in this paper are listed below and detailed in the following sections.

1. Drought impact on hydropower dams.
 - 1.1 Systematic vulnerability of the Brazilian electricity sector.
 - 1.2 Optimistic operation of the electricity sector.
 - 1.3 Generation head loss.
2. Delay on the completion of power projects.
3. Electricity price reduction.
4. Outdated operational information to estimate power generation.

Table 2
Usual causes of an electricity supply crises.

Causes of an electricity supply crises	
Drought.	Rapid demand growth.
Depletion of hydropower storage reservoirs.	Lack of investment in generation capacity.
Fuel shortfall (gas, diesel, coal, oil).	Power plants forced stoppage for security reasons.
Power plant and transmission lines breakdowns.	Steep surges in demand from heat waves or cold periods.
Natural disasters (earthquake, tsunamis, wildfires).	Heat wave impact in thermoelectric power plants. Due to reduction in the power plant cooling system efficiency or environmentally based shutdown requirements.
Lack of funds to operate plants.	

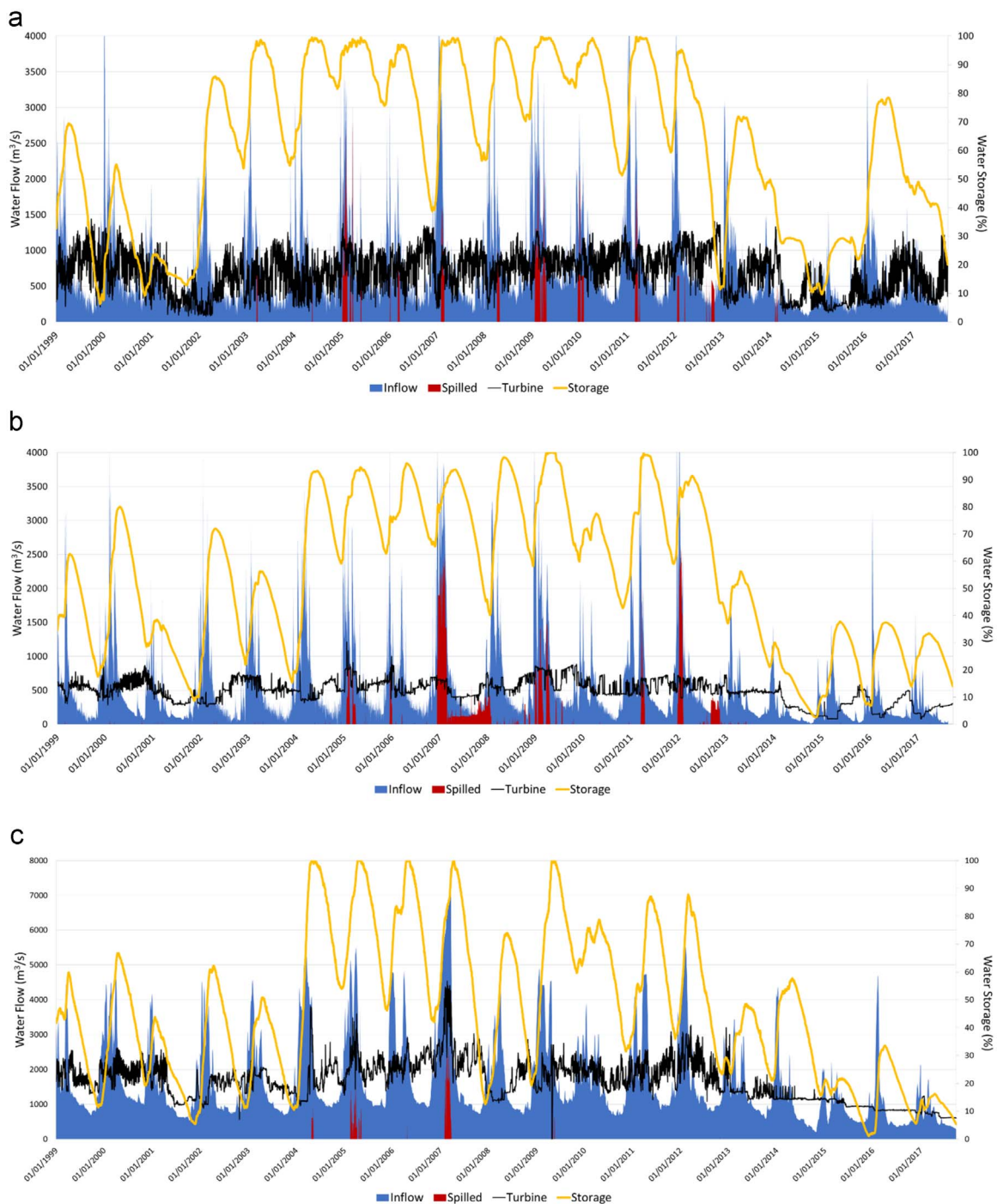

Fig. 3. Inflow, spilled and turbine flows (m³/s), and energy storage (%) for (a) Furnas, (b) Três Marias (c) and Sobradinho Reservoirs.

Other causes for the energy crises, which are constantly published in the literature, are presented in Table 2. More details can be seen in [13–16,55].

2.1. Drought impact in hydropower dams

Several authors are working on the effects of droughts over hydro-power plant reservoirs [56–59]. This section presents the impact of the drought in the hydroelectric generation and proposes operational improvements. The following graphs present the inflow of water entering the reservoir (inflow), the water passing through the dam without generating electricity (spilled), the water that passed through the turbine to generate electricity (turbine), and the storage percentage of the

reservoir (storage). The outflow of the dam is the sum of the spilled and the turbine flow. The information was obtained from the Brazilian Electricity Grid Operator [52]. Comparing the electricity generation in 2012 with 2015, there is a shortage of 110 TWh of hydropower generation.

Fig. 3(a) shows that the average inflow of the Furnas Reservoir over a year is 900 m³/s. This flow has a maximum hydropower potential of 4.8 GW at the cascade downstream (not considering losses due to depletion of the generation head). With the drought from 2013 until 2015, the inflow was reduced to 250 m³/s, which contributed to a generation reduction of 3.5 GW of electricity generation in the Grande and Paraná Rivers. In 2016 the reservoir recovered to 80% of its capacity, however, this was only possible as the outflow was kept low. Furnas is a very

important reservoir to assure electricity generation during the dry period. Its storage capacity should be used as much as possible, even if the outflow during the wet period has to be considerably reduced.

Fig. 3(b) shows that the inflow at Três Marias Dam reduced from an average $600 \text{ m}^3/\text{s}$ to around $200 \text{ m}^3/\text{s}$ during the drought in 2014, a reduction of approximately 1.3 GW. Note that in 2014, the Três Marias Reservoir reached a storage level of 10%, and the Sobradinho Reservoir was maintained at 60%, see Fig. 3(c). This should not happen as the Sobradinho Reservoir is shallow and the flooded area varies from 1145 km^2 at its minimum level to 4196 km^2 at its maximum level in the driest region of Brazil. It is estimated that an average of $167 \text{ m}^3/\text{s}$ of water evaporates from the Sobradinho Reservoir [60], which is equivalent to a loss of 0.5 GW. Thus, the Três Marias Reservoir should be given preference to regulate the flow of the São Francisco River instead of the Sobradinho Reservoir. Note that this happened in 2015 as shown in Fig. 3(c). In 2015, the outlet flow at the Sobradinho Reservoir reduced from $2000 \text{ m}^3/\text{s}$ to $800 \text{ m}^3/\text{s}$.

As mentioned in the introduction (Table 1), the Brazilian energy sector suffers from regular energy crisis, whose main reason is an extended period with lack of rain. With the intent of evaluating if there is a climatological pattern of rain cycles, the annual natural river flow² [52] of the Ilha Solteira Dam (Paraná River) and Sobradinho Dam (São Francisco River) were analysed together with the crises caused by droughts. Both the Paraná and São Francisco rivers represented, respectively, 39.7% and 9.8% of the total power generation in Brazil in 2008 [61]. Analysing Fig. 4, especially the seven years running average, it can be seen that the energy crisis in 2015 has a reduction in river flow. Going back in time it can be seen that in 2001 there was another considerable reduction in river flow. This pattern repeated for the crisis in the Northeast Region in 1987 and the crises of 1963 and 1953. The year of 1971, with low rainfall, had no crisis because several dams with large reservoirs has just been recently built, for example Furnas and Três Marias, that could store energy for more than a year or two to supply the relatively low demand at that time. This pattern of 10–15 year drought cycles should be analysed in future work and taken into account when planning the Brazilian electricity sector, with the intention to avoid future energy crises caused by extended droughts, which seem to be inevitable.

2.1.1. Vulnerability of the Brazilian electricity sector

Fig. 5 shows that 70% of the energy storage capacity of Brazil is located in the area surrounded by the red line. This is a small area to contain a big share of the Brazilian energy storage potential. In addition, it is influenced by similar climatic conditions [62]. When there is a drought in this region, the energy storage reservoirs do not fill up and the country has to increase thermoelectric generation, increase electricity prices, reduce the demand for electricity and possibly ration electricity consumption. The concentration of 70% of the energy storage of the country in one region with a similar climatic behaviour results in a huge vulnerability for the Brazilian electricity sector and is the major cause for most energy crises in Brazil.

In 1970, the energy stored in the reservoirs, when full, had the capacity to supply energy for two to three years [63]. Today, with the current demand for energy, the full storage reservoirs can store energy for only around 4–5 months. The total storage capacity stopped increasing, but the monthly demand continues to increase. In addition, new dams in the Amazon region will considerably increase the generation during the wet period, however generate an insignificant amount of energy during the dry period. Thus, the system will rely less on energy storage, resulting in a more volatile hydrological variation that compromise the energy security of Brazil.

In 2015, the storage reservoirs were very low. As shown in Fig. 1,

² Natural River Flow is the estimated river flow is there were no reservoirs upstream, i.e. there is no interruption in the river flow.

the previous energy storage potential were around 160 TWh at the end of the wet period. In 2015, the energy storage potential at the end of the wet period was 90 TWh. Compared to previous years, the energy storage potential contributed with only 70 TWh less in 2015.

2.1.2. Optimistic operation of the electricity sector

For a hydrothermal energy system such as in Brazil, the decisions on which power plants to operate affect the immediate electricity prices and also have an impact on the resource availability over the longer term. In this case, grid operators need to apply a more complex decision process to ensure prudent selection of power plant operation, taking into account the uncertainty of the hydropower resource availability in the future. For example, if grid operators rely on hydropower plants alone and fail to maintain sufficient reservoir levels, hydro generation can be weakened in dry years. The shortage will need to be covered by traditional thermal power plants, which will result in higher electricity prices to the consumers. On the contrary, if the water reserve in the reservoirs is too high, the reservoirs waste hydropower potential in wet years, which will result in inefficient use of thermoelectric and hydropower resources [64].

In Brazil, the Brazilian Electricity Grid Operator is responsible for the generation and transmission of electricity. As opposed to a complex decision process that involves resource evaluation over a longer time-frame (as described above), ONS operates the Brazilian grid based on a minimum cost principle. Since hydropower plants present lower production marginal costs, they are usually prioritised to generate electricity. As a result, the reservoir levels are often alarmingly low which renders the power system vulnerable.

Particularly at the end of 2012, ONS was far too optimistic with the Brazilian hydrology, with the robustness of the electricity sector and, possibly, with the intention to justify the recent low energy tariffs. It ordered to spill some of the water in the Furnas Reservoir (Fig. 3(a)), wasting hydroelectric potential, to increase peak generation in the Grande and Paraná Rivers, and reduce thermoelectric generation. Serra da Mesa Reservoir also spilled huge amounts of water with the intention to increase hydropower generation in the Tocantins River Dams, wasting huge amounts of hydropower potential. Even Três Marias spilled water with the same intent (Fig. 3(b)).

This article estimates that 4 GW were wasted through spillage during the three final months of 2012, which is equivalent to 9 TWh, due to the mistaken decision to spill water in the dams upstream to generate electricity in the dams downstream. As a longer-term alternative, ONS could have generated electricity at that moment with thermoelectric plants. This decision unfortunately put Brazil in a fragile position to assure hydroelectric generation during the three following dry years, 2013, 2014 and 2015.

2.1.3. Generation head loss

When there is lack of rainfall, apart from the depletion of water stored in the reservoirs, the generation head of the storage dams reduces. With a smaller generation head, more water is required to generate the same amount of electricity, as in the potential energy equation. Table 3 presents the main storage reservoir dams and their generation reduction due to their operation with low head. As the drought kept the reservoirs low throughout 2014 and 2015, there was an average generation loss of 3 GW during July 2014 and July 2015 due to head loss, which is equivalent to 25 TWh.

2.2. Delay on the completion of power projects

From 2012–2016 there were a series of delays in the construction of hydropower and wind power projects or the construction of transmission lines [65–67]. Table 4 shows the delays in the completion of hydropower projects as of May 2014 [68]. As these delays changed from time to time, for more precise analysis, the yearly “Ten-Year Energy Plan” was compared to find a more specific impact of the delays [51]. It

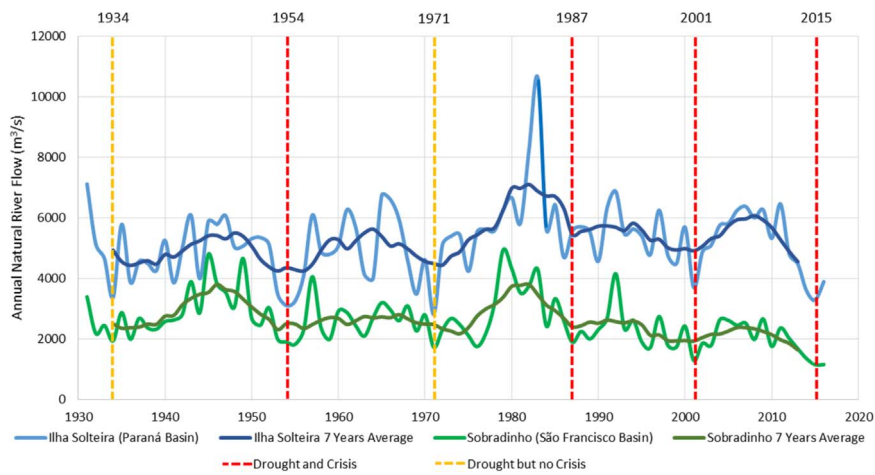

Fig. 4. Annual natural river flow time series of Ilha Solteira and Sobradinho and the energy crises in Brazil.

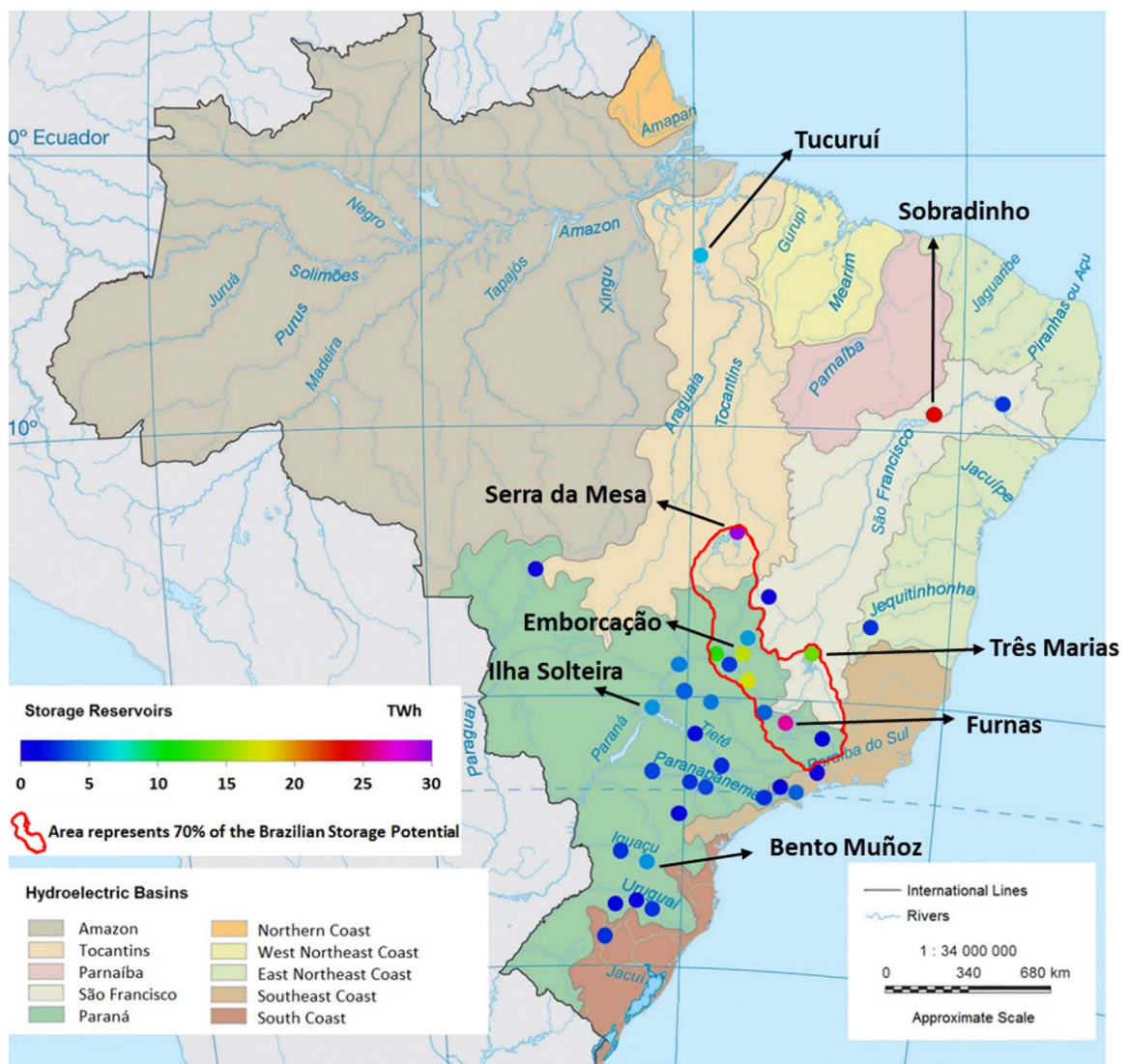

Fig. 5. Brazilian hydropower storage reservoirs highlighting an area with 70% of this potential [50].

Table 3
Generation loss due to generation head reduction in the main storage reservoirs.

Dams	Maximum Head (m)	Minimum Head (m)	Power (GW)	Generation Loss (%)
Tucuruí	65,5	43,1	8535	34,2
Sobradinho	27,2	15,2	1,05	44,1
Serra da Mesa	117,2	74,5	1275	36,4
Três Marias	50,2	26,9	0396	46,4
Furnas	90	72	1312	20,0
Emborcação	130,3	84,3	1192	35,3
Itumbiara	80,2	55,2	2,28	31,2
Bento Munhoz	135	93	1676	31,1
Barra Grande	148,37	118,37	0,6984	20,2

Table 4
Delay on the completion of power projects [68].

Dam	Power (MW)	Average Generation (GW)	Delay (months)	Auction schedule	Date expected
Belo Monte	11,233	4.419	15	Jan-2016	Apr-2017
Jirau	3750	2.185	17	Jan-2015	Jun-2016
Santo Antônio	3150	2.218	18	Dec-2012	Jun-2014
Teles Pires	1820	0.915	9	Apr-2015	Jan-2016
São Manoel	700	0.421	8	May-2018	Jan-2019
Sinop	400	0.24	6	Jan-2018	Jul-2018
Baixo Iguaçu	350	0.179	48	Jan-2013	Jan-2017
São Roque	135	0.091	15	Jan-2016	Apr-2017
Salto Apicás	45	0.023	6	Jan-2018	Jul-2018

is estimated that a 5.5 GW generation potential was lost between July 2014 and July 2015 due to delays on the completion of Power Projects, which is equivalent to 48 TWh in a year.

2.3. Electricity price reduction

The National Energy Policy number 579/2012 had the main objective of reducing the price of electricity for general customers, but had a negative impact on several electricity generation companies, especially public ones, and created uncertainties in the electricity sector [69]. ANEEL (Brazilian Electricity Regulatory Agency) approved on 24 January 2013 new tariffs to reduce the electricity bill. The average reduction was 20.2% [70]. However, as the spot market electricity price (PLD) increased to 269 \$/MWh³ in 2014, see Fig. 6, some energy intensive industries, for example steel and aluminium, reduced or even stopped production and sold electricity at spot market, to increase its profits. The reduction of electricity consumption by the industry buffered the increase in consumption in the other sectors and the overall energy consumption increase from 2012 to 2013 and 2014 was 2.5% and 2.3%, respectively. With the energy sector in crisis, the electricity price reduction did not last long and the price of electricity to the general customer increased by around 70% from 2014 to 2015.

2.4. Outdated operational information to plan the electricity sector

A number of the Brazilian hydropower dams were built several decades ago as shown in Table 5. Some of the data used to estimate the outlet flow, power generation, storage capacity used to optimize the electricity sector are outdated and date from the construction of these dams. Over the years there has been an increase in sedimentation, reduction of the original efficiency of the turbines and changes in evaporation. Regular studies have been developed to update flow data [72,73] and evaporation data [74].

Sedimentation of reservoirs affects the capacity of the reservoirs to

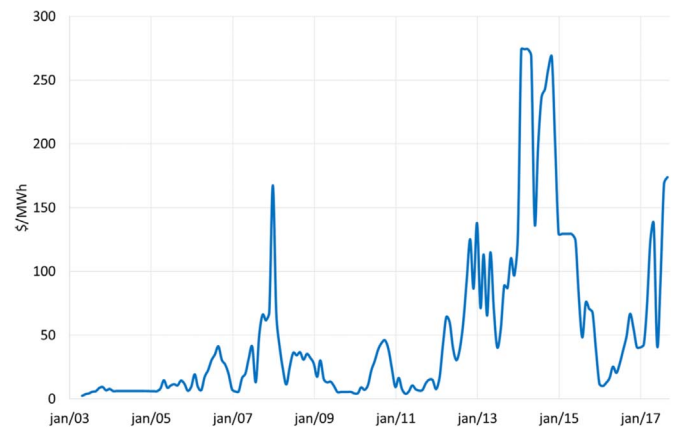

Fig. 6. Electricity price in the spot market (PLD) [71].

Table 5
Years of construction completion and operation start-up of major dams.

Dams	Year of completion	Dams	Year of completion
Itaipu	1982	Tucuruí	1984
Furnas	1963	Emborcação	1977
Sobradinho	1979	Itumbiara	1981
Três Marias	1961	Bento Muñoz	1980

store water, and thus energy. In some dams, sedimentation might have an insignificant impact in reservoirs with adequate depth and steep margins. However, in shallow and large reservoirs, such as the Sobradinho Reservoir, sedimentation can have a real impact on storage capacity. It would be appropriate to review the bathymetry of these shallow and large reservoirs to calculate the amount of storage loss during their operation.

The outlet flow that passes through the dams is estimated by the amount of electricity generated. As the dams are ageing, there is an efficiency loss. With efficiency loss, a bigger flow is required to generate the same amount of electricity. Thus, the system operator may believe there is a lower water flow than the actual value recorded. A review of the turbines, reservoirs and the expected generation of the plants is necessary for a more precise accountability of energy and water resources.

Another aspect that should be taken into account is that the water extraction for agricultural, industrial and other uses is not properly accounted for and affects the electricity generated in the dams. Increased extraction of water from the river basins for agriculture and other activities is intensifying with irrigated plantations, especially in the São Francisco water basins [75]. It should be noted that water for irrigation has priority over electricity generation. However, it is important to have data on water extraction to improve electricity generation planning and operation.

2.5. Review of the causes of the energy crisis in 2015

Table 6 presents a comparative review of the energy crisis causes discussed in Section 2. The loss of generation data is an estimate by the authors based on the assumptions described in each sub-section. It allows a better understanding of the problems that most contributed to the energy crisis and those aspects of the electricity sector should be given priority to avoid future crises. It is outside the scope of this paper to show the relative importance of the “Electricity Price Reduction” and “Outdated Information” due to the complexity and lack of updated information on the plants, respectively.

It was found that the drought had an overall impact of 110 TWh in hydropower generation between July 2014 and July 2015, from which 25 TWh were due to head loss and 70 TWh from lack of stored

³ One American dollar (USD) is assumed to worth three Brazilian reals (BRL) [109].

Table 6
Impact of each energy crisis cause between July 2014 and July 2015.

Causes	Impact (TWh)	Description
1) Drought Impact	110	The severe drought in Brazil considerably reduced the hydropower generation of the country. The three causes below (lack of energy stored, optimistic operation and generation head loss) are included in the drought impact cause.
1.1) Vulnerable System/Lack of Energy Stored	70 (from drought impact)	Not enough energy stored during the drought reduced the generation capacity of the country. The cause below (optimistic operation) is included in the lack of energy stored impact cause.
1.2) Optimistic Operation	9 (from lack of energy stored)	At the end of 2012, ONS spilled water, without generating electricity, in the dams upstream of the main rivers with the intention to increase peak generation in the dams downstream.
1.3) Generation Head Loss	25 (from drought impact)	The depleted storage reservoirs reduced the hydropower generation head in the storage reservoir. This has a considerable impact on the hydropower generation potential of the country.
2) Project Delays	48	Generation and transmission project delays had a large impact on the energy crisis.
3) Electricity Price Reduction	–	The electricity price reduction was buffered by the sharp increase in the spot market electricity price and hence, reduction in industrial production. Thus, it is difficult to estimate the impact on the increase of electricity consumption.
4) Outdated Information	–	The uncertainties in the data used to plan energy sector and the real data are unknown.
Total	158	Note that the lack of energy stored and the generation head loss are included in the drought impact.

hydropower in July 2014. A share of 9 TWh from the lack of stored hydropower cause were due to optimistic operation of the grid in 2013. In addition, 48 TWh were not generated due to delays in the construction of new power plants. These impacts sums up to a reduction in power generation of 158 TWh, not including the impacts of electricity price reduction in the increase in energy consumption, and the outdated operational information from power plants.

3. Impacts from the 2015 energy and water crises

The impact of curtailing services goes beyond the immediate inconvenience of a lack of electricity. There are many impacts resulted from the energy and water crisis in 2014–2015. Some selected impacts are listed below and presented in the following sections. Impacts of the 2001 crisis, which also applies to the 2015 crisis, are reduction in industrial production, loss of credibility of Brazil in the global market, reduction of foreign investment in the country and others are discussed in more details in the references in the introduction section.

- 1) Impact on the Water Supply Sector.
- 2) Impact on the Food Supply Sector.

The methodology applied in this section is a qualitative and descriptive analysis based on the literature with the intention of highlighting the main impacts of an energy crisis to better prepare for future crises. It should be noted that studies on the economic impact of power rationing are scarce in the literature [13]. Until now, there are no comprehensive studies of the full impact of the 2001–2002 crisis on the Brazilian economy [13].

General impacts of energy crises, which are constantly published in the literature, are presented in Table 7. More details are presented in [13–16,55]. The impact of longer duration crises and chronic shortages of power is even more difficult to estimate [13]. Lack of power can deter new investments, job creation, and economic development in

Table 7
General impacts of an electricity supply crises.

General impacts of an electricity supply crises	
Electricity price increases, which impact harder on the poor who cannot afford the increases in price.	Possible financial crisis in the power industry, which makes it more difficult to stop the energy crisis.
Blackouts - periods of minutes, hours or days without electricity.	Brownouts - periods of minutes, hours or days with a drop in voltage in the electrical power supply system.
Impact on the economy, reduction in GDP or reduction in GDP growth.	Reduction in production of high electricity consumption products, such as aluminium.
Reduction in electricity consumption.	Increase in CO ₂ emissions for electricity supply, due to the use of inefficient thermoelectric generation for base load.
Electricity rationing.	Reduced reliability of power supply.
Loss in industrial production.	High costs for recovering the entire power system during an energy crisis.

general. In countries where the power system is not reliable, rich customers invest in the installation of back-up generators, which significantly increase the cost of “doing business” [13].

3.1. Impact on the water supply sector

As the Brazilian power generation sector relies heavily on hydroelectric generation, there are times when the stored water is used to ensure electric generation while the water supply for other activities is compromised [76–78]. For example, in 2013 and 2014 much of the water stored in the Paraibuna Reservoir, the head of the Paraíba do Sul River Basin, was used to generate electricity due to the energy crisis. In January 2015, the reservoir fell below the level required for electricity generation, restricting water supply, and compromising the water quality in the Rio Paraíba do Sul [79].

As shown in Fig. 7 the useful water stored volume in the Paraíba do Sul River fell from 55% in January 2014–0% in January 2015. This did not happen even in the 2001 crisis. The flow of the dam just before the Guandu Water Treatment plant, responsible for supplying drinking water to Rio de Janeiro, in September 2014 was 115 m³/s, and in September 2015, fell to 75 m³/s, not enough to supply water for the city of Rio de Janeiro. This shows that in 2014 water was used for electricity generation when it should have been conserved for water supply. For instance, the Paraibuna Dam, main head reservoir of the Paraíba do Sul River, reached the second half of 2014 with a storage capacity lower than 25%, but it still discharged an average of 63.5 m³/s during the same period, when the discharge should have been reduced to conserve water [80].

A similar trend happened in the São Francisco River. As shown in Fig. 3(c) the Sobradinho Reservoir reached 1% of the total storage capacity at the end of 2015, which could have resulted in disastrous consequences for the supply of water below the dam if the wet period had not started as expected.

It has reached a point that the Paraíba do Sul, São Francisco and

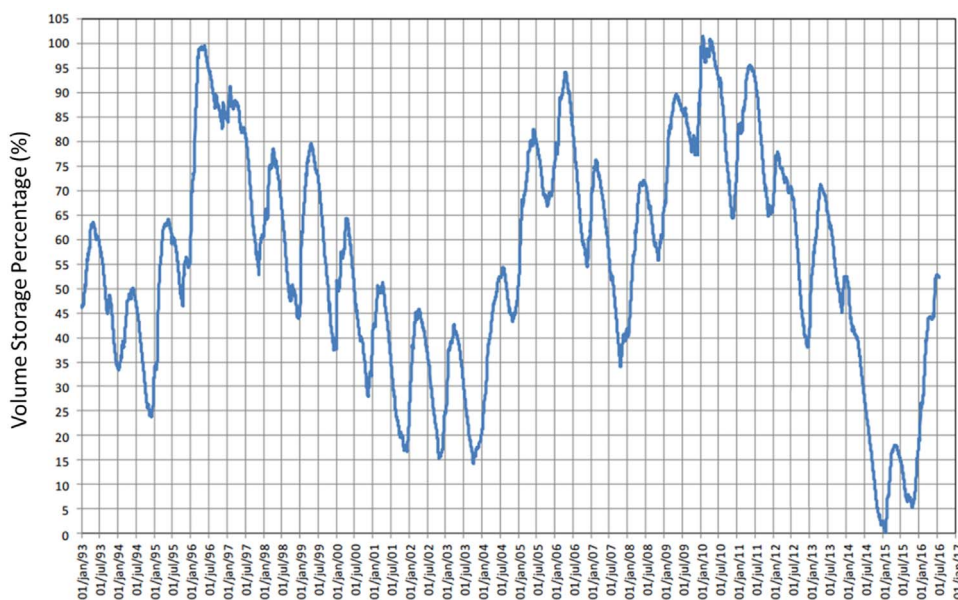

Fig. 7. Useful water storage volume in the Paraíba do Sul Reservoirs [81].

other river basins should prioritised the guarantee of water supply over hydroelectric generation. They should maintain a minimum allowed storage level, to guarantee water supply in case of consecutive dry years.

3.2. Impact on the food supply sector

Regarding food supply, the Brazilian economy is strongly based on primary activities, such as agriculture and livestock. Therefore, the lack of rains during the season could result in losses in some crops, as well as productivity impacts on sectors like beef industry (swine, cattle and chicken), besides animal by-products (especially chicken eggs and milk production).

According to the Brazilian Institute of Geography and Statistics (IBGE) [82], most of the Brazilian food industry was not impacted by droughts observed between 2013 and 2015. On the contrary, Table 8 show a slightly increasing trend in the slaughter of swine and chicken, as well as in milk and egg production. The only exception was the slaughter of cattle, which registered almost 9.6% reduction in 2015, in comparison with the previous year. Nevertheless, other factors not related to weather conditions, like stronger international market competition and higher logistics costs, could also explain decreased cattle beef sales in 2015.

The Brazilian agricultural production data series, presented in Table 8, reveals a clear impact caused by lack of rainfall in 2013, 2014 and 2015. The crop productivity diminished 6.9% in 2014, in comparison with previous seasons, after a long period of consistent growths. In this case, it can be stated that weather conditions observed in 2013

Table 8 Slaughtered animals, production of animal by-products and agricultural production in the Brazilian food sector (2012–2016) [82].

Food Sector Data	2012	2013	2014	2015	2016
Cattle (millions animals)	31	34	34	31	30
Swine (millions animals)	36	36	37	39	42
Chicken (millions animals)	5244	5394	5496	5796	5860
Milk from dairy cattle (10 ⁶ m ³)	22	23	25	24	23
Chicken eggs (10 ⁶ dozens)	2695	2740	2825	2927	3098
Planted area (10 ⁶ ha)	71	75	78	79	79
Crop production (10 ⁶ t)	968	1038	1015	1043	1036
Yield (t/ha)	13.6	13.9	13.0	13.2	13.1

and 2014, two years drier than the average, provoked a reduction in crop development in rural areas in Brazil. Moreover, after a slight recover in the following season (+ 2.0%), the crop yield fell once more in 2016 (– 1.2%), as a side effect of rain levels in 2015, also lower than regular pattern.

4. Possible solutions to energy and water crises in Brazil

This section focuses on structural solutions specifically for the crisis of the electricity sector in 2015 in Brazil and points out some of the solutions already in place. These are presented below:

- 1) Emergency strategies to face the crisis in 2015.
- 2) Diversify generation sources.
- 3) Increase and decentralize energy storage.
- 4) Hybrid biomass generation and energy crop storage.
- 5) Variable energy costs.

Other solutions suggested for the 2001 crisis, which still apply to the 2015 crisis, such as increase in reserve power capacity, increase in backup thermoelectricity generation and others are discussed in the introduction section.

The methodology applied in this section is a qualitative and descriptive analysis based on the literature with the intention of proposing possible solutions to prevent energy and water crises in the future. It is outside the scope of this paper to show the relative importance of the solutions presented.

General solutions to energy crises, which are constantly published in the literature, are presented in Table 9. More details on the main characteristics, time frame, estimated cost, prerequisites and best practices are presented on [13–16,55,83–85].

4.1. Emergency strategies to face the crisis in 2015

Some emergency strategies use to mitigate the energy crisis in 2015 were to increase thermal power generation to the maximum, accelerate completion of wind power projects, reduce demand through the increase of electricity price (Fig. 8), allow back-up generators to operate as base load, and others mentioned throughout the paper.

Apart from the gas (12.0 GW), coal (3.1 GW), oil (4.8 GW) and biomass (11.0 GW) thermoelectric generation capacity in 2014 [51],

Table 9
General solutions to tackle an electricity supply crises.

General solutions to tackle an electricity supply crises	
Demand side options	Supply side options
Increase industrial electricity tariffs.	Rehabilitate existing plants and transmission.
Increase residential electricity tariffs.	Accelerate completion of plants under construction.
Mass media campaign.	Offer purchase power agreements on a short-term basis.
Public sector energy conservation.	Add capacitor banks to reduce transmission losses.
Volunteer rationing.	High speed reciprocating engines.
Compulsory rationing.	Install advanced metering systems to reduce losses.
Efficient lighting program.	Lease power generation barges, or fixed gas turbines.
Replacement to more efficient equipment.	Lease or purchase used power plant equipment.
Daylight savings.	Fuel switching.
Shift equipment operation to off-peak hours.	Soften environmental restrains.
Smart metering.	

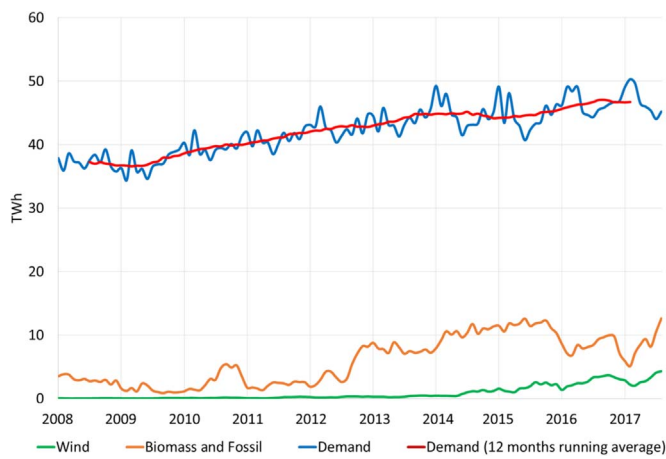

Fig. 8. Electricity demand, biomass and fossil fuels and wind power generation (ONS data).

there was an estimated 9 GW of back-up capacity with small-scale generators running with diesel and gas. These generators are operated mainly to generate electricity during peak hours for service buildings and industry, when the price of electricity is higher for large consumers, and to guarantee their supply of electricity. ANEEL established a policy to subsidise the operation of fossil fuel generators to operate as base load and reduce the need for hydroelectric generation [86]. Note that the contribution from these self-owned generators is not included in the

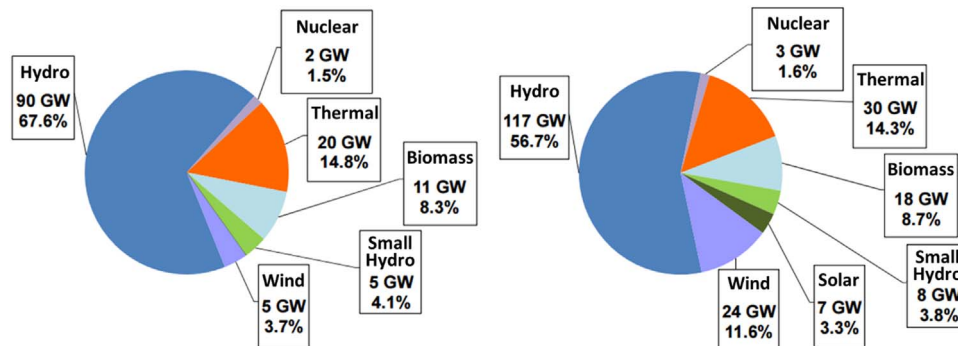

Fig. 9. Brazilian generation capacity in (a) 2014 and (b) prediction for 2024 [51].

graphs in Figs. 2 and 8.

In 2015, the additional cost of thermoelectric generation was transferred to the consumer. On the demand side, the economic recession has led to a drop of 1.3 GW consumption from January to June 2015 in comparison to the same period in 2014, as shown in Fig. 8. Assuming that the demand was increasing in rate of 2 GW per year between January 2010 and January 2014, there was a relative reduction of 3.3 GW compared with the expected increase in demand. This reduction in demand was a result of the rapid increase in electricity prices for industry and the general public and it reduced the likelihood of energy rationing.

4.2. Diversify energy generation sources

As mentioned previously, Brazil relies heavily on hydropower generation to meet its electricity demand, which accounts for 78% of the electricity mix on average in the last ten years. A comparative study of the diversity of electricity generation by Molyneaux et al. [87] confirmed a relatively low diversity in the Brazilian energy matrix, which scored a diversity index of 0.3 compared to a world average of 0.75. The lack of diversity in the sources of electricity supply poses a risk in generation stability and potential price volatility [88]. Fig. 9 presents the electricity generation capacity of 2014 and the expected electricity generation capacity in 2024. As it can be seen, the sources of energy that will increase percentage size are wind and solar power, with the proportional reduction in large-scale hydropower. The role of wind and solar power in reducing risks in the Brazilian hydro-thermal power systems is detailed in [89].

The diversification of the Brazilian electricity grid has accelerated since the 2001 crisis, however, it is still happening at a slow pace. As new dams in the North are being built, this diversification will continue sluggish. The more diverse the energy generation sources, the more secure the electricity sector become [90,91].

Distributed generation sources are strong candidates for the diversification of electricity sources, such as solar, small hydro, biomass, wind power and co-generation [92], which have a great potential in Brazil [93,94].

A specific application of decentralized generation that is very interesting in Brazil is the implementation of solar power to supply air-conditioning demand. This is because, the higher the solar irradiation, the higher the air-conditioning demand in Brazil and the higher the solar power generation. In order to avoid the need of inverters in this type of solar power solution, the air-conditioning system can operate with a direct current motor. This is a more affordable and efficient solution to supply peak air-conditioning demand in large buildings.

4.3. Increase and decentralize energy storage

Hydroelectric generation capacity is predicted to increase 36% by 2024 but the energy storage capacity is expected to increase only 0.9%

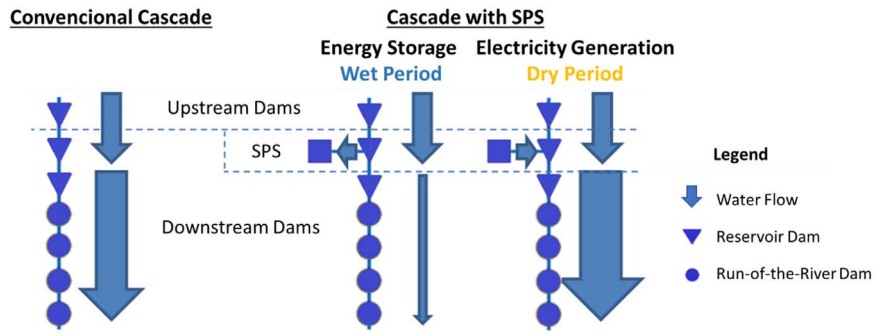

Fig. 10. Operation of (a) conventional hydroelectric plants (b) SPS during periods of high water availability (c) SPS during periods of low water availability.

by 2024 [51], which will be 216 TWh, equivalent to a generation of 23 GW for a whole year. As the Brazilian Government still wants to develop its hydropower capacity to keep generating most of its electricity from hydropower, there is the need to increase the country's storage capacity.

Recently, the remaining hydraulic energy storage potential in Brazil was assessed [95]. From a portfolio of 180 identified projects, the 25 best total 34.1 TWh, from which 54% represents a smaller environmental and social impacts. However, the Ministry of Mines and Energy have not yet considered these projects for future studies.

An efficient approach to increase the energy storage of Brazil is with Seasonal-Pumped-Storage (SPS). Apart from storing energy in daily and weekly cycles, SPS has also the possibility to have an overall yearly storage cycle. Fig. 10(a) presents the conventional hydropower cascade generation scheme where the reservoir dams are located upstream the river controlling the hydropower generation in the dams downstream. With the combination of a SPS plant and hydroelectric dams in cascade, as shown in Fig. 10(b) and (c), it is possible to increase the water basin storage capacity with a new reservoir built in parallel to the river basin. Water can then be pumped to the SPS reservoir or used for generating electricity in accordance with the country's needs for energy storage and power generation [50]. Fig. 10(b) represents the overall water flux in the water basin with a SPS plant during the wet period. The exceeding electricity in the grid, at night and during weekends, is used to pump water to the SPS upper reservoir storing energy and reducing the generation in the dams in cascade downstream. The energy storage process in the SPS has an efficiency of 70–75%. With the inclusion of the cascade, the overall storage efficiency increases considerably and may even result in a net generation gain. This happens if the increase in storage upstream the river basin reduces the water spillage of the dams in cascade downstream the SPS plant. During the dry period or when there is a shortage of energy in the grid, such as in daytime, SPS generates electricity using the stored water and increases the generation of the dams in cascade downstream, as shown in Fig. 10(c) [50].

The Brazilian south is an interesting location to install a Seasonal-Pumped-Storage plant because, while there were a drought in the Southeast regions in 2001 and 2015, there was an increase in rainfall in the Southern region, which resulted in a considerable water spillage in the dams. This would increase the overall energy security of the country because if there is no water to store energy in the Southeast region, water from the South region can be used to store energy. The 13 projects presented in [96] have the potential to increase the Brazilian storage capacity by 140%.

The main objective of SPS in the Brazilian energy sector is to complement the highly seasonal hydroelectric generation profile, which is predicted to have a similar pattern to the graph in Fig. 11(a) in 2023. The hydropower seasonality becomes more apparent in 2023 due to the completion of new dams in the Amazon region without storage reservoirs. Thus, there will be considerably more hydropower generated during the wet period.

As shown in Fig. 11(b), to resolve this generation imbalance, one to

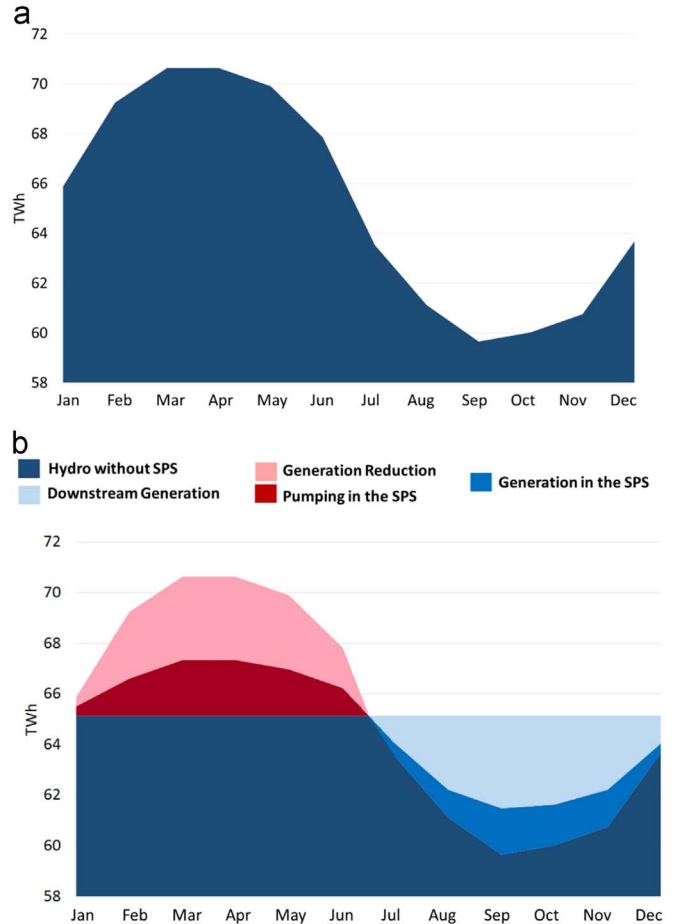

Fig. 11. Estimated hydropower generation for 2023 (a) without SPS (b) and with SPS [97].

three SPS plants with a summed installed capacity of 3 GW could be used pump an average of 0.5–2 GW monthly (Pumping in the SPS) during the wet period, storing energy and water. This would reduce the hydropower generation in the dams downstream in a monthly average of 1–3.5 GW (Generation Reduction). During the dry period, the SPS would generate an average of 0.4 – 1.5 GW (Generation in the SPS), including the 25% losses, and would increase the generation in the dams downstream at an average of 1–3.5 GW (Downstream Generation). In his way, a few SPS projects could change the Brazilian hydropower profile to the generation profile shown in Fig. 11(b). This way the seasonality caused by the hydropower generation in the Amazon region, without storage, can be resolved with SPS projects with a total installed capacity of 3 GW.

4.4. Hybrid biomass generation and energy crop storage

A study of sugar-cane bagasse boilers shows that other biomass, such as eucalyptus, could be burned in the same boiler during the sugarcane off-season months [98]. This study shows an overall gain of 12.6 TWh per year with hybrid biomass generation with the already installed sugarcane based biomass generation capacity. This generation potential during the wet period could be used during a drought, to complement the lack of hydropower generation. At the moment, the residual heat is used in the sugar and ethanol production process. In order to generate only electricity during the off-season, combined cycle should be included to increase the overall efficiency of electricity generation. Brazil has a great potential for agricultural residues based electricity generation, other than sugarcane bagasse that should be explored.

Energy Crop Storage (ECS) is a concept that provides long-term storage in energy crops with the intention to reduce the yearly variation of electricity supply. The main concept behind the ECS scheme is to allow eucalyptus or other plantations to grow when there is a year with less need to generate thermoelectricity and to use the biomass stored in a year with emergence need for thermoelectricity. For example, in a year with good rainfall, during the dry period, the biomass power plant would operate at full load and, during the wet period, it would not operate, as most of the electricity would be generated with hydropower, resulting in an overall capacity factor of 50%. This would allow the eucalyptus plantations to grow higher, storing extra biomass for future use. In a dry year, the plant would operate near full capacity throughout the whole year, which could result in a capacity factor close to 90%. This would then consume the biomass previously stored in the eucalyptus plantation, as the plantation reached a higher average height. This scheme is explained in Fig. 12. More details can be seen in [99].

4.5. Variable energy costs

The Brazilian Government initiated in 2015 a price variation scheme to give more flexibility to the cost of electricity with the intention to repay the higher costs resulting from thermal electricity generation. The scheme also has the intention to conserve electricity by reducing electricity consumption. Four different levels of price tariffs were created, the Green Flag, the cheapest option with no increase to the tariff, the Yellow Flag, with an increase of \$ 3.75/MWh, and the Red Flag, which is divided into two levels, level one with an increase of \$ 7.5/MWh, and level 2 with an increase of \$ 11.25/MWh [100].

During the wet period, Brazilian hydropower will supply most of the electricity demand. However, during the dry period, thermoelectricity

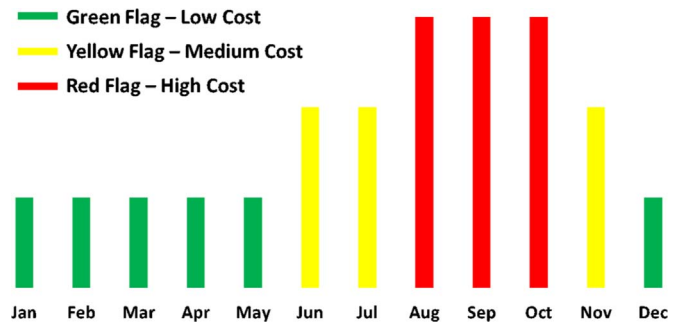

Fig. 13. Likely changes in electricity costs over a typical year.

will guarantee the supply. Thus, it is expected that in the short-term the Green, Yellow and Red flags might behave predominantly as shown in Fig. 13, due to the lack of energy storage and the need for thermo-electricity generation during the dry period. During the wet period, the price of electricity is low (Green Flag), then during the months of June, July and November, in the dry period, when the hydrology is not favourable, the price of electricity is at an average level (Yellow Flag), and during the worst months of the dry period, August, September and October, the price of electricity reaches its maximum (Red Flag). Therefore, financial return on electric self-generation will be higher during the dry season. This is presented in more details in the PDE 2026 [101].

5. Discussion

This paper discussed the considerable risk Brazil is accepting owing to more than 70% of its electricity matrix being based on unpredictable hydropower generation. Considering that Brazil has several electricity generation source alternatives, the country should diversify its power generation portfolio. Electricity auctions and policies should continue to incentive different energy resources within the country.

Brazil presents huge potential to harness renewable energy in all its 27 states, especially for electricity generation. In the Northeast region, wind power generation has increased exponentially, owing to regular public auctions realized since 2009. The increase in wind generation is expected to continue. From 2014 on, solar power is emerging as a promising option for the Northeast states, in poor municipalities that present the highest solar potential in the country.

The Midwest region the economy is based on livestock and agriculture. Thus, there is a considerable amount of residues, mainly from cattle and soybeans, which could be used to produce biogas, burned or

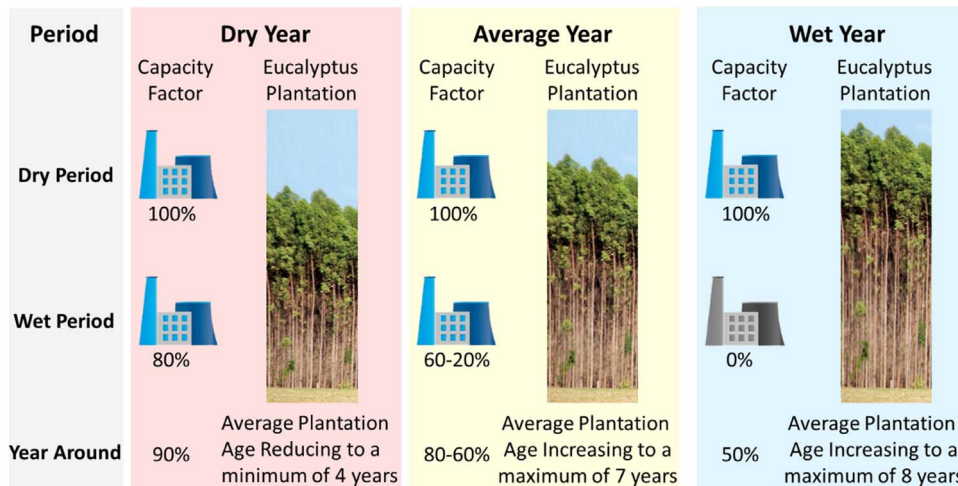

Fig. 12. Energy Crop Storage scheme suited to accommodate the Brazilian Energy Sector.

gasified to generate electricity and reduce greenhouse gases emissions. Nevertheless, these resources are wasted every year. In North region, where most of the Amazon rainforest is located, biomass and small hydropower plants are the most suitable options to avoid oil and diesel consumption in small power generators. There is also the possibility to build new large run-of-the river dams in the region.

The Southeast region is where the major cities are located and concentrates most of Brazilian industries. There is a large potential for distributed generation, especially solar power, and for biomass, such as residues from livestock, as well as sugarcane bagasse. Lastly, the South region also has a great wind generation potential, which has been harnessed. Wind generation in South region is expected to increase. The region also has great potential with biogas from pig farms and biomass from agriculture residues.

Another alternative proposed in this paper to increase the energy security of the country is to increase the energy storage capacity with Seasonal-Pumped-Storage power plants. With SPS, the variation of electricity generation can be controlled with the increase in energy storage. In case of a drought, the energy stored in SPS plants and the thermoelectric plants will have a much better capability of guaranteeing the energy supply of the country.

SPS plants are in operation in several countries, especially in countries with a high presence of hydropower generation, such as Austria [102,103], Switzerland [104], Norway [105], Sweden [106] and the State of Washington [107]. Countries that used to have a high share of hydropower generation, such as Italy and France also have SPS plants [108]. These SPS plans not only store energy seasonally, they generate electricity during peak hours, store energy for weekly variations, reduce the intermittency of renewable energy sources, reduce transmission costs, increase the country's energy security, contribute for water supply in irrigation projects and provides ancillary services.

As mentioned in Section 2.1, Brazil suffers with severe hydropower reductions with cyclical patterns of 10–15 years. SPS plants could be designed with pluri-annual storage capacities and store energy during years with high hydropower availability and generate electricity during years of low hydropower availability. Energy security is an important aspect that should be taken into account when planning of the electricity sector, with the focus on reducing the risks of energy crises and improving quality of supply.

6. Conclusion

The paper discusses the major underlying causes that led Brazil to the 2015 electricity crisis. It shows that the drought in 2015 had an impact of 110 TWh in hydropower generation, from which 25 TWh are due to head loss and 70 TWh are from lack of stored hydropower in July of 2014. From the lack of stored hydropower, 9 TWh were due to optimistic operation of the grid in 2012 and 2013. In addition, 48 TWh were not generated due to delays in the construction of new power plants. Other causes, such as electricity price reduction and outdated information to plan the electricity sector were analysed qualitatively.

Analysing the natural river flow of key dams from 1931 until 2017, this paper suggests that hydropower generation in Brazil has a cyclical pattern with 10–15 years, in which there are consecutive years with higher than the average hydropower generation and others with lower than the average hydropower generation. The periods of drought in this cyclical pattern usually coincides with energy crises periods due to the reduction in hydropower generation.

As Brazil relies heavily on hydropower for electricity generation, during droughts the need for electricity generation can affect the supply of water for other uses. This happened to the Paraíba do Sul River, where water was used for electricity generation and it reached a point that there were restrictions in the supply of drinking water to the population. Another impact from the water crisis happens in the agriculture and livestock sectors, where the lack of rain contributed to a reduction in productivity.

Strategic measures identified to reduce future crises are to increase thermal power generation to the maximum; allow back-up generators to operate as base load; promote the reduction of demand through electricity prices increase and to further promote wind generation.

With the intention of preventing future energy crises, the paper then shows the potential alternatives to improve electricity supply security in Brazil. This is proposed particularly in terms of the creation of variable energy costs; diversifying and widening the share of renewable sources, such as hybrid biomass generation; and decentralizing the country energy storage potential with seasonal pumped-storage and energy crop storage.

Acknowledgements

We would like to thank CAPES/BRAZIL (Brazilian Federal Agency for Support and Evaluation of Graduate Education) and IIASA (International Institute for Applied Systems Analysis) for the research grant (99999.000613/2016-09) and research fellowship (ZVR 524808900), respectively, as part of the CAPES/IIASA Postdoctorate program.

References

- [1] Hong S, Bradshaw C, Brook B. Evaluating options for the future energy mix of Japan after the Fukushima nuclear crisis. *Energy Policy* 2013;56:418–24.
- [2] Clark W, Lund H. Civic markets, the case of the California energy crisis. *Int J Glob Energy Issues* 2001;16(4):328–44.
- [3] Bushnell J. California's electricity crisis: a market apart? *Energy Policy* 2004;32(9):1045–52.
- [4] Watts D, Ariztia R. The electricity crises of California, Brazil and Chile: Lessons to the Chilean market. In: *Proceedings of the Power Engineering Large Engineering Systems Conference, Halifax*; 2002.
- [5] Javaid M, Hussain S, Maqsood A, Arshad Z, Arshad M, Idrees M. Electrical energy crisis in Pakistan and their possible solutions. *Int J Basic Appl Sci* 2011;11(5).
- [6] Kessides I. Chaos in power: Pakistan's electricity crisis. *Energy Policy* 2013;55:271–85.
- [7] Valasai G, Uqaili M, Memon H, Samoo S, Mirjat N, Harijan K. Overcoming electricity crisis in Pakistan: a review of sustainable electricity options. *Renew Sustain Energy Rev* 2017;72:734–45.
- [8] Alam A, Malik I, Abdullah A, Hassan A, Faridullah A, Awan A, Ali G, Zaman K, Naseem I. Does financial development contribute to SAARC'S energy demand? From energy crisis to energy reforms. *Renew Sustain Energy Rev* 2015;41:818–29.
- [9] Ahmed Z. Electricity crisis of Bangladesh: result of organizational inefficiency? *Energy Environ Res* 2011;1(1):12–23.
- [10] Nagayama H, Kashiwagi T. Evaluating electricity sector reforms in Argentina: lessons for developing countries? *J Clean Prod* 2007;15:115–30.
- [11] Shrestha R. Electricity crisis (load shedding) in Nepal, its manifestations and ramifications. *Hydro Nepal: J Water Energy Environ* 2010;6:7–17.
- [12] Araújo J. The case of Brazil: reform by trial and error? *Electricity Market Reform*. Cambridge: Elsevier; 2006. p. 565–94.
- [13] Energy Sector Management Assistance Program. *Implementing power rationing in a sensible way: Lessons learned and international best practices*. Washington: UNDP and World Bank; 2005.
- [14] Pasquier S. *Energy efficiency series: saving electricity in a Hurry*. France: International Energy Agency; 2011.
- [15] Energy Sector Management Assistance Program. *Managing an electricity shortfall: a guide for policymakers*. Washington: The World Bank; 2010.
- [16] Energy Sector Management Assistance Program. *Best practices for market-based power rationing: implications for South Africa*. Washington: The World Bank; 2011.
- [17] Coyle E, Simmons R. *Understanding the global energy crisis*. West Lafayette: Purdue University Press; 2014.
- [18] Sovacool B. An international assessment of energy security performance. *Ecol Econ* 2013;88:148–58.
- [19] Newbery D. *Issues and options for restructuring electricity supply industries*. Cambridge: The Cambridge-MIT Institute; 2002.
- [20] Yu W, Pollitt M. Does Liberalisation cause more electricity blackouts? Evidence from a global study of newspaper reports. Cambridge: University of Cambridge; 2009.
- [21] Wamukonya N. Power sector reform in developing countries: mismatched agendas. *Energy Policy* 2003;31:1273–89.
- [22] Besant-Jones J. *Reforming power markets in developing countries: what have we learned?* Danvers: The World Bank; 2006.
- [23] Dias R, Cachapuz P, Cabral L, Lamarão S. *Panorama do Setor de Energia Elétrica no Brasil*. Cent da Mem da Eletr no Bras 1998.
- [24] Bardelin C. *Os efeitos do racionamento de energia elétrica ocorrido no Brasil em 2001 e 2002 com ênfase no consumo de energia elétrica*. São Paulo: Universidade de São Paulo - Escola Politécnica; 2004.
- [25] Departamento Nacional de Águas e Energia Elétrica, Comissão de Coordenação de

- Racionamento de Energia Elétrica da Região Sul, DNAEE, Brasília; 1986.
- [26] Magalhães J. Racionamento de energia no Nordeste, Comissão Parlamentar de Inquérito (CPI), Brasília; 1987.
- [27] Eletrobrás, A Energia Elétrica no Brasil - da primeira lâmpada à Eletrobrás, Biblioteca do Exército Editora, Rio de Janeiro; 1977.
- [28] Moita R. Entry and externality: hydroelectric generators in Brazil. *Int J Ind Organ* 2008;26:1437–47.
- [29] Rosa L, Lomardo L. The Brazilian energy crisis and a study to support building efficiency legislation. *Energy Build* 2004;36:89–95.
- [30] Scaramucci J, Perin C, Pulino P, Bordoni O. Energy from sugarcane bagasse under electricity rationing in Brazil: a computable general equilibrium model. *Energy Policy* 2006;34:986–92.
- [31] Franchito S, Rao B. Rainy-season duration estimated from OLR versus Rain Gauge data and the 2001 drought in Southeast Brazil. *Appl Meteorol Climatol* 2008;47:1493–9.
- [32] Simoes S, Barros A. Regional hydroclimatic variability and Brazil's 2001 energy crisis. *Manag Environ Qual* 2007;18(3):263–73.
- [33] Souza L, Soares L. Electricity rationing and public response. *Energy Econ* 2007;29:296–311.
- [34] Araújo J. A Questão do Investimento no Setor Elétrico Brasileiro: Reforma e Crise. *Rev Nova Econ* 2002;11(1):77–95.
- [35] Cavaliero C, Silva E. Electricity generation: regulatory mechanisms to incentive renewable alternative energy sources in Brazil. *Energy Policy* 2005;33:1745–52.
- [36] Pinto Jr. H. The issue of unfinished structural and institutional reforms: the case of Brazil's power industry. *Rev De l'Energy* 2003;544:103–11.
- [37] Hamaguchi N. Will the market keep Brazil lit up? Ownership and market structural changes in the electric power sector. *Dev Econ* 2002;40(4):522–52.
- [38] Jardim J, Ramos D, Martini J, Reis L, Tahan C. Brazilian energy crisis. *IEEE Power Eng Rev* 2002;22(4):21–4.
- [39] Losekann L. The second reform of the Brazilian electric sector. *Int J Glob Energy Issues* 2008;29(1/2):75–86.
- [40] Tankha S. From market to plan: lessons from Brazilian power reforms on reducing risks in the provision of public services. *Policy Soc* 2008;27:151–62.
- [41] Rosa L, Silva N, Pereira M, Losekann L. The Evolution of Brazilian Electricity Market. *Evolution of Global Electricity Markets: New Paradigms, New Challenges, New Approaches*. Rio de Janeiro: Elsevier; 2013. p. 435–59.
- [42] Barroso L, Pereira M, Kelman R, Lino P, Rosenblatt J. Can Brazil learn from California? *IEEE Power Eng Rev* 2002;22(8):17–23.
- [43] Hirst D. Project finance issues threaten gas-fired power development in Brazil. *Oil Gas J* 2001;99(49):78–83.
- [44] Prates J. Brazil's energy crisis complicates progress in gas, power markets, but outlook brightening. *Oil Gas J* 2001;99(42):77–84.
- [45] Fernandes E, Oliveira J, Oliveira P, Alonso P. Natural-gas-powered thermo-electricity as a reliability factor in the Brazilian electric sector. *Energy Policy* 2008;36:999–1018.
- [46] Bardelin C. The effects of electricity rationing in Brazil in 2001 and 2002 with an emphasis on energy consumption [Master's Thesis]. São: São Paulo University; 2004.
- [47] Dias H. Brazil 2001 energy crisis - The albras approach, In: *Proceedings of the 133rd Technical TMS Annual Meeting*, Carlotte; 2004.
- [48] PPI This Week, IPB hindered by Brazil's energy crisis, vol. 16, no. 24, 2001, p. 6.
- [49] Souza Filho C, Zullo Jr. J, Elvidge C. Brazil's 2001 energy crisis monitored from space. *Int J Remote Sens* 2004;25(12):2475–82.
- [50] Hunt J, Freitas M, Pereira Júnior A. Enhanced-pumped-storage: combining pumped-storage in a yearly storage cycle with dams in cascade in Brazil. *Energy* 2014;78:513–23.
- [51] Energy Research Office, Ten-year Plan for Expansion of the Electric Sector - 2024, EPE, Rio de Janeiro; 2015.
- [52] Brazilian Electricity Grid Operator, Operation History, 23 02 2016. [Online]. Available: <<http://www.ons.org.br/historico/>>.
- [53] Silva R, New increase in electricity is expected to 2016, 08 December 2015. [Online]. Available: <http://www.gazetaonline.com.br/_conteudo/2015/12/noticias/dinheiro/3917205-novo-aumento-na-energia-eletrica-esta-previsto-para-2016.html>.
- [54] Carpio L. Cointegration to estimate long-term electricity prices in periods of rationing: the case of the Brazilian hydrothermal system. *Electr Power Syst Res* 2015;121:351–6.
- [55] International Energy Agency. *Saving Electricity in a Hurry*. Paris: IEA; 2005.
- [56] Shadman F, Sadeghipour S, Moghavvemi M, Saidur R. Drought and energy security in key ASEAN countries. *Renew Sustain Energy Rev* 2016;53:50–8.
- [57] Melo D, Scanlon B, Zhang Z, Wendland E, Yin L. Reservoir storage and hydrologic responses to droughts in the Paraná River basin, south-eastern Brazil. *Hydrol Earth Syst Sci* 2016;46:73–88.
- [58] Coelho C, Oliveira C, Ambrizzi T, Reboita M, Carpenedo C, Campos J, Tomaziello A, Pampuch L, Custódio M, Dutra L, da Rocha R, Rehbein A. The 2014 southeast Brazil austral summer drought: regional scale mechanisms and teleconnections. *Clim Dyn* 2016;46(11–12).
- [59] Oliveira V, Mello C, Viola M, Srinivasan R. Assessment of climate change impacts on streamflow and hydropower potential in the headwater region of the Grande river basin, Southeastern Brazil. *Int J Climatol* 2017.
- [60] Pereira S, Pruski F, Silva D, Ramos M. Evaporation in the Sobradinho reservoir and impacts on the river flow due to its construction. *Braz J Environ Agric Eng* 2009;13(3).
- [61] Brazilian Electricity Regulatory Agency, Atlas de Energia Elétrica do Brasil, ANEEL, Brasília; 2008.
- [62] National Institute for Space Research, Waterbasin - Weather Forecast Center Climate and Studies, INPE, 24 July 2016. [Online]. Available: <<http://energia1.cptec.inpe.br/>>.
- [63] Rocha A. Brazilian Energy Agenda, In: *Proceedings of the 1st Forum of Energy - FGV and COOPEFURNAS*, Rio de Janeiro; 2003.
- [64] Pereira M, Campodónico N, Kelman R. Long-term hydro scheduling based on stochastic models, September 23–25, Zurich; 1998.
- [65] Fuchs V. Blaming the weather, blaming the people: socio-environmental governance and a crisis attitude in the Brazilian electricity sector [April-June]. *Ambient Soc* 2016. [April-June].
- [66] Philip F. Amazon dams and waterways: Brazil's Tapajós Basin plans. *Ambio* 2015:426–39.
- [67] OECD. *OECD environmental performance reviews: Brazil 2015*. Paris: OECD Publishing; 2015.
- [68] PSR, Noel Rosa and the electricity sector bill in 2014 and 2015, PSR, Rio de Janeiro; 2014.
- [69] Godoi M, MP 579: one 11/09 year for the electricity sector, Canal Energia, 25 July 2016. [Online]. Available: <<http://www.canalenergia.com.br/zpublisher/materias/Retrospectiva.asp?Id=97289&a=2013>>.
- [70] Brazilian Electricity Regulatory Agency, ANEEL announced reduction of electricity tariffs, ANEEL, Brasília; 2013.
- [71] Brazilian Electric Energy Commercialization Chamber, Average price of the CCEE, CCEE, 25 July. [Online]; 2016. Available: <<http://www.ccee.org.br>>.
- [72] Brazilian Electricity Grid Operator, Consistency and Restoration Studies of Natural Flow Series in the Parnaíba, Jequitinhonha and Doce River Basins, INS, Brasília; 2008.
- [73] Hidalgo I, Fontane D, Lopes J, Andrade J, de Angelis A. Adjusting the efficiency curves from Hydroelectric plants. *J Water Resour Plan Manag* 2014;140(1).
- [74] Brazilian Electricity Grid Operator. Net evaporation in hydroelectric plants. Rio de Janeiro: ONS; 2004.
- [75] Mendes L, Barros M, Zambon R, Yeh W. Trade-off analysis among multiple water uses in a hydropower system: case of São Francisco River Basin, Brazil. *J Water Resour Plan Manag* 2015;141(10).
- [76] Hill M. Every drop counts: an examination of the causes, consequences, and solutions to the drought crisis in Brazil's southeast region. *Int J Sustain Policy Pract* 2017;13(2):2–18.
- [77] Targa M, Batista G. Benefits and legacy of the water crisis in Brazil. *Rev Ambient e Agua* 2015;10(2):234–9.
- [78] Vilanova M, Balesstieri J. Exploring the water-energy nexus in Brazil: the electricity use for water supply. *Energy* 2015:415–32.
- [79] National Water Agency. Monitoring hydraulic reservoirs system report of the Paraíba do Sul River. Brasília: ANA; 2015.
- [80] Brazilian Electricity Grid Operator. Daily preliminary operation report (Title in Portuguese: informativo Preliminar Diário da Operação). Brasília: ONS; 2014.
- [81] National Water Agency. Daily monitoring report of the Paraíba do Sul River. Brasília: ANA; 2016.
- [82] Brazilian Institute on Geography and Statistics, IBGE, 18 September. [Online]; 2017. Available: <<https://sidra.ibge.gov.br>>.
- [83] Bernard J, Roland M. Load management programs, cross-subsidies and transaction costs: the case of self-rationing. *Resour Energy Econ* 2000;22:161–88.
- [84] Kimura O, Nishio K. Responding to electricity shortfalls: Electricity-saving activities of households and firms in Japan after Fukushima. *Int Assoc Energy Econ* 2015;5:51–71.
- [85] Nooij M, Lieshout R, Koopmans C. Optimal blackouts: empirical results on reducing the social cost of electricity outages. *Energy Econ* 2009;31:342–7.
- [86] Ministry of Mines and Energy, Ordinance No. 44 of 10th, March of 2015, MME, Brasília; 2015.
- [87] Molyneux L, Wagner L, Froome C, Foster J. Resilience and electricity systems: a comparative analysis. *Energy Policy* 2012;47:188–201.
- [88] Stipen D, Cheng V. Electricity supply crisis in Brazil: Problems and Opportunities, In: *Proceedings of the 10th Conference on Sustainable Development of Energy, Water and Environment Systems (SDEWES)*, Dubrovnik, Croatia; 2015.
- [89] Schmidt J, Cancellari R, Pereira Jr A. The role of wind power and solar PV in reducing risks in the Brazilian hydro-thermal power system. *Energy* 2016;115(3):1748–57.
- [90] Silva R, Marchi Neto I, Seifert S. Electricity supply security and the future role of renewable energy. *Renew Sustain Energy Rev* 2016;59:328–41.
- [91] Prado Jr F, Athayde S, Mossa J, Bohlman S, Leite F, Oliver-Smith A. How much is enough? An integrated examination of energy security, economic growth and climate change related to hydropower expansion in Brazil. *Renew Sustain Energy Rev* 2016;53:1132–6.
- [92] Ofgem and DTI. *Review of distributed generation*. London: DTI; 2007.
- [93] Energy Research Office. *Photovoltaic distributed generation in Brazil*. Rio de Janeiro: EPE; 2014.
- [94] Martins V. Analysis Policies of potential public in distributed generation of feasibility in Brazil. Rio de Janeiro: Federal University of Rio de Janeiro; 2015.
- [95] Energy Research Office. *Electricity generation expansion planning - identification and classification of potential regulation reservoirs*. Rio de Janeiro: EPE; 2015.
- [96] Hunt J, Freitas M, Pereira Junior A. A review of seasonal-pumped-storage combined with dams in cascade in Brazil. *Renew Sustain Energy Rev* 2017;70:385–98.
- [97] Energy Research Office. *Ten-year plan for expansion of the electric sector - 2023*. Rio de Janeiro: EPE; 2013.
- [98] Maluf A. Thermo-economic assessment of the cogeneration in the sugar mills using bagasse, straw, vinasse biogas and generation in the off-season, UNICAMP: Doctorate Theses, Campinas; 2014.
- [99] Hunt J, Guillot V, Freitas M, Solari R. Energy crop storage: an alternative to resolve the problem of unpredictable hydropower generation in Brazil. *Energy*

- 2016;101:91–9.
- [100] Brazilian Electricity Regulatory Agency, Consumer Tariffs, ANEEL, 26 July. [Online]; 2016. Available: <http://www.aneel.gov.br/tarifas-consumidores/-/asset_publisher/e2INtBH4EC4e/content/bandeira-tarifaria/654800?inheritRedirect=false>.
- [101] Energy Research Office. Ten-year plan for expansion of the electric sector - 2023. Rio de Janeiro: EPE; 2013.
- [102] Weber A, Beckers T, Feuß S, Hirschhausen C, Hoffrichter A, Weber D. Potential for the provision of pumped-storage power plants in Switzerland, Austria and Germany (Title in German: potenziale zur Erzielung von Deckungsbeiträgen für Pumpspeicherkraftwerke in der Schweiz, Österreich und Deutschland). Berlin: BfE - Department of Economic and Infrastructure Policy; 2014.
- [103] Hecker C, Zauner E, Pellingner C, Carr L, Hötzl S. Modelling the flexible energy supply of hydroelectric power plants in Europe (Title in German: Modellierung der flexiblen Energiebereitstellung von Wasserkraftwerken in Europa), In: Proceedings of the International Energy Management Conference, Vienna University of Technology., Vienna.
- [104] Nordmann R, Remund J. L'évolution des besoins de stockage au fur et à mesure de la sortie du nucléaire, dans l'hypothèse où l'on remplace 70% du nucléaire par du photovoltaïque. Zurich: Swissolar; 2012.
- [105] Solvang E, Charmasson J, Sauterleute J, Harby A, Killingtveit A, Egeland H, Andersen O, Ruud A, Aas O. Norwegian hydropower for large-scale electricity balancing needs. Trondheim: SINTEF; 2014.
- [106] Ess F, Haefke L, Hobohm J, Peter F, Wünsch M. Importance of international hydropower storage for the energy transition (Title in German: bedeutung der internationalen Wasserkraft-Speicherung für die Energiewende). Berlin: Prognos; 2012.
- [107] Reed L. Banks Lake Pumped-Storage project (North Dam Site), in In: Proceedings of the Mid-C Seminar, 27 July 2016, Wenatchee, WA; 2016.
- [108] Hydrelect, Work in France & the World (Title in French: Ouvrages, France & Monde), 15 December. [Online]; 2016. Available: <<http://www.hydrelect.info/articles.php?Lng=fr&pg=364>>.
- [109] Google Finance, Brazilian Real (R\$) ⇔ US Dollar (\$), 01 May. [Online]; 2015. Available: <<https://finance.google.com/finance?Q=CURRENCY:BRL>>.